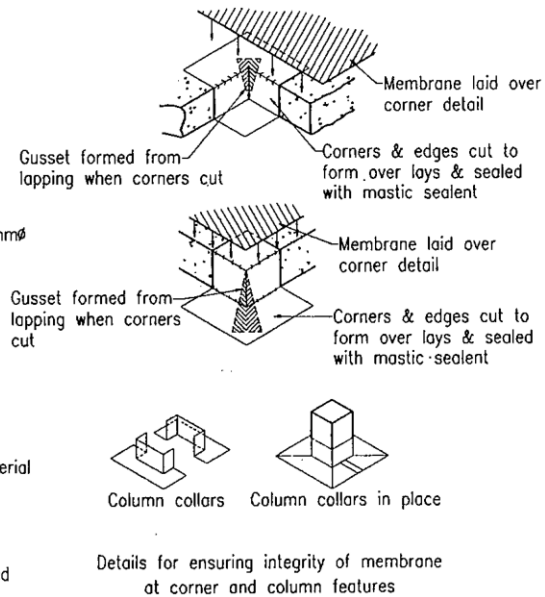
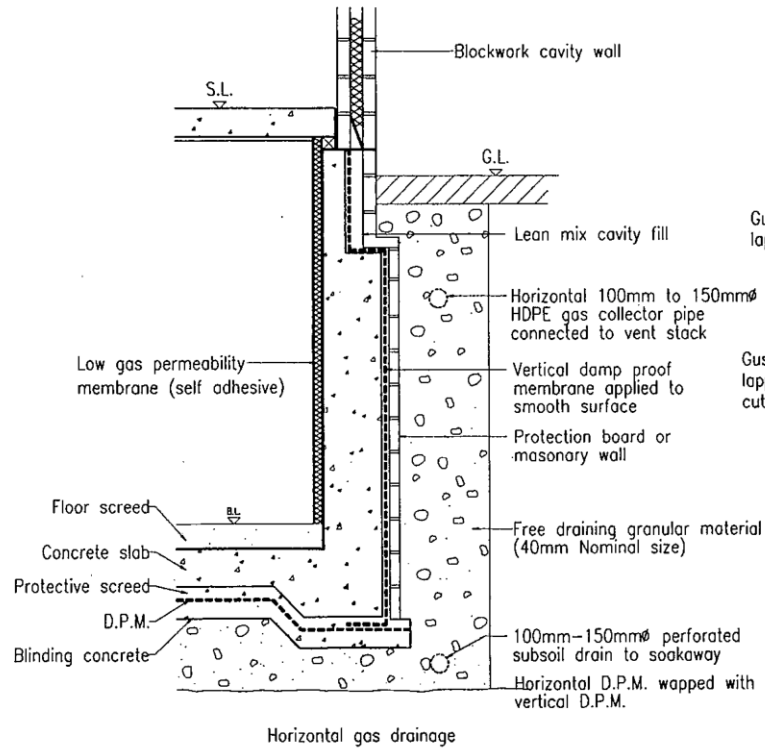

Illustration 1: Typical Detail of Flexible Membrane Protection for Buildings



Source: EPD's Landfill Gas Hazard Assessment Guidance Note

Not to Scale

Illustration 2: Subfloor Venting

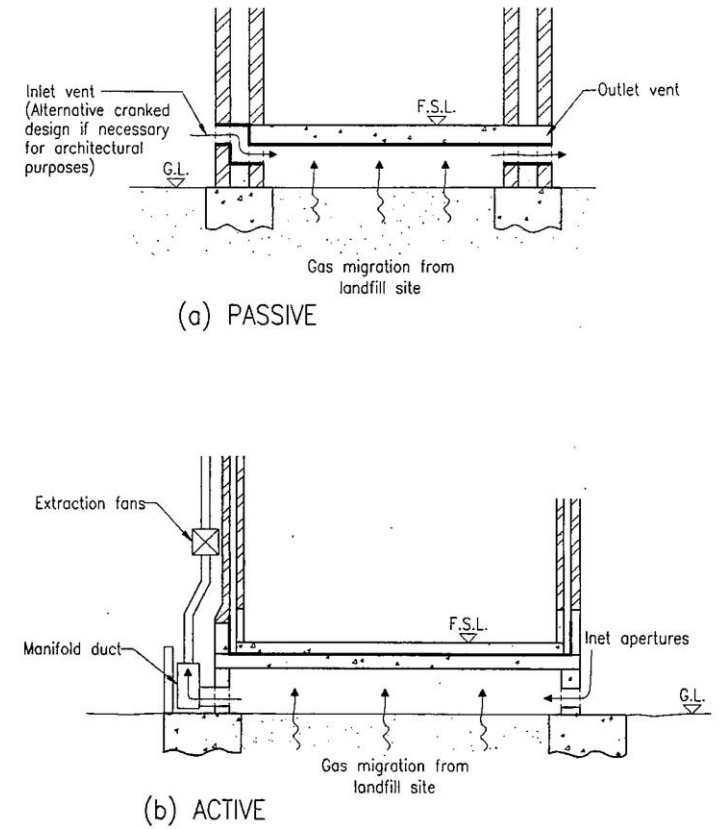

Source: EPD's Landfill Gas Hazard Assessment Guidance Note

Not to Scale

Illustration 3: Natural Material Cut-off Barrier

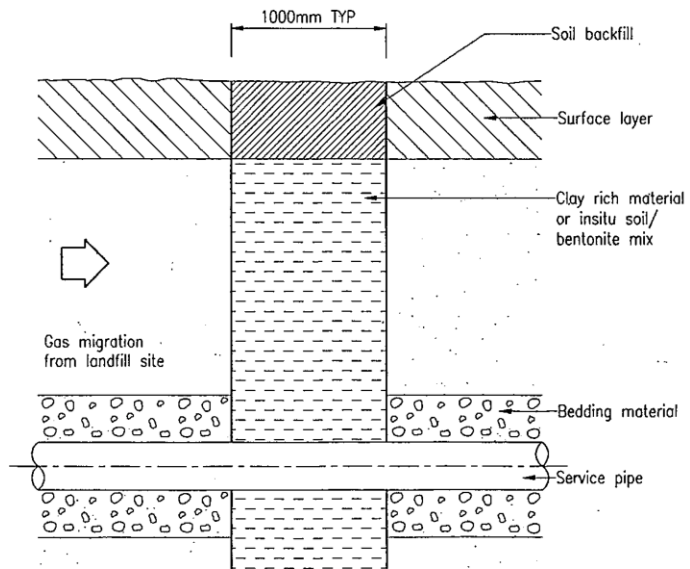

Source: EPD's Landfill Gas Hazard Assessment Guidance Note

Illustration 4: Typical Detail of Collar Seal (Cross-section)

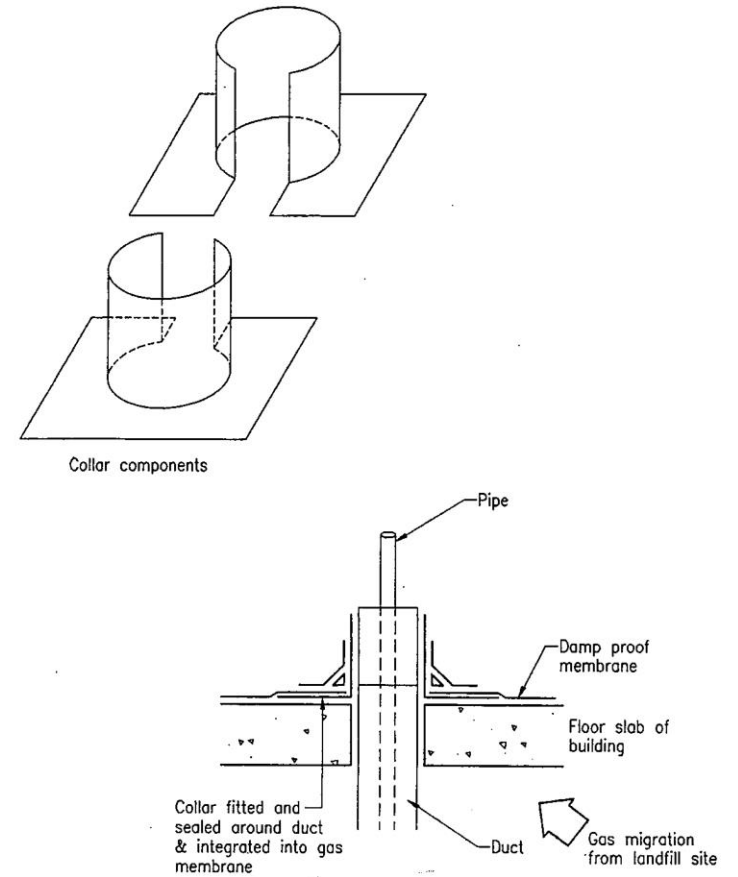

Not to Scale

Source: EPD's Landfill Gas Hazard Assessment Guidance Note

Not to Scale

Illustration 5: Vented Manhole (Cross-Section)

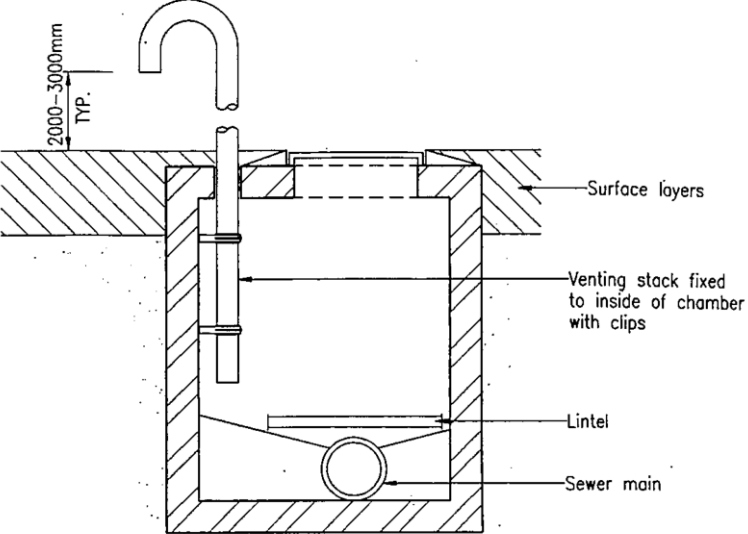

Source: EPD's Landfill Gas Hazard Assessment Guidance Note

Not to Scale

Illustration 6: Vented Gas Interceptor Cavity (Cross-Section)

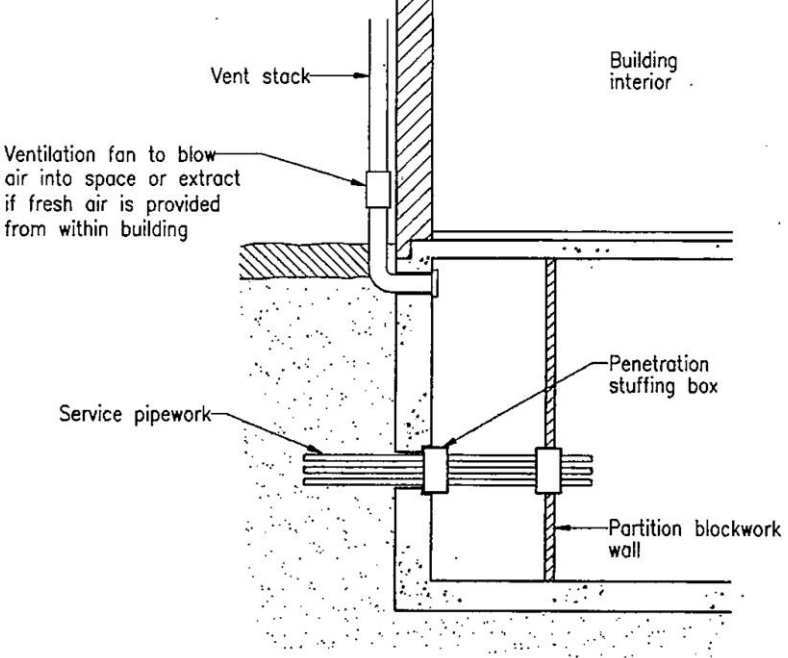

Source: EPD's Landfill Gas Hazard Assessment Guidance Note

Not to Scale